

Project · Reference number

Date

**Application**

Garden luminaire with shielded light source.  
For lighting paths, stairs and gardens.

**Product description**

Luminaire made of aluminium alloy, aluminium and stainless steel  
Crystal glass with optical structure  
Luminaire with mounting plate for bolting onto a foundation or an anchorage unit  
Mounting plate with two pitch circles:  
ø 70 mm, 3 elongated holes 7 mm wide  
ø 100 mm, 3 elongated holes 9 mm wide  
Luminaire can be aligned on the mounting plate around 360°  
Mounting bracket with connection box and 3-pole terminal 4<sup>□</sup> for connection of mains supply cable max. 3 × 2.5<sup>□</sup>  
Lampholder GX 24 d-2  
Ballast (EEI=B1)  
230 V ~ 50 Hz  
Prepared for PF correction capacitor  
Safety class I  
Protection class IP 65  
Dust tight and protection against water jets  
Impact strength IK06  
Protection against mechanical impacts < 1 joule  
CE – Conformity mark  
Weight: 7.5 kg

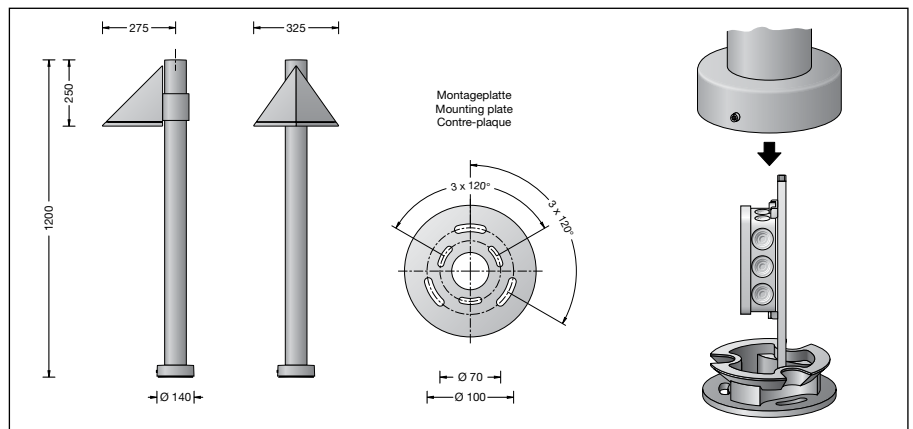

www.bega.com

**Lamp**

Compact fluorescent lamp  
TC-T · 18 W · GX 24 d-2

Osram: Dulux T Plus 18 W /... 1200 lm  
Philips: PL-T 18 W 1200 lm

Please note the lamp manufacturers' operating instructions.

**Article No. 88 871**

Colour graphite, white or silver  
graphite – article number  
white – article number + **W**  
silver – article number + **A**

**Accessory**

**70 895** Anchorage unit  
Anchorage unit with mounting flange made of galvanised steel. Total length 400 mm.  
3 stainless steel fixing screws M 8.  
Pitch circle ø 100 mm.

A separate instructions for use can be provided upon request.